

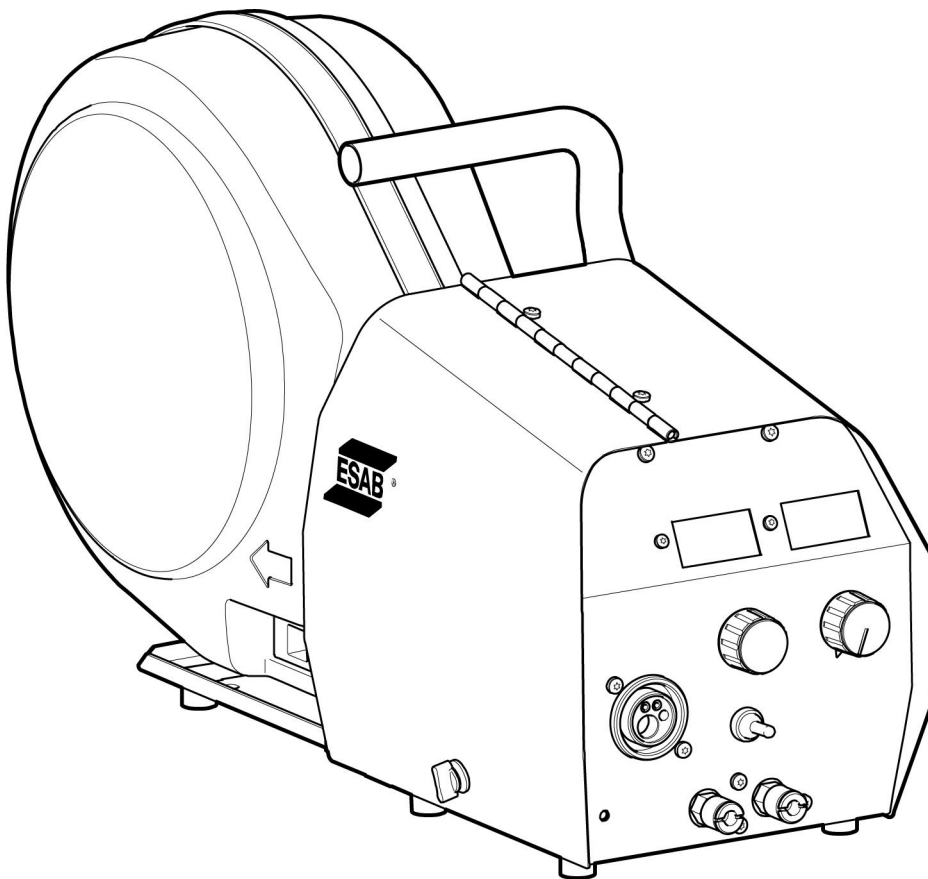

Warrior™ Feed 304, Warrior™ Feed 304w



Instruction manual

1	SAFETY	3
1.1	Meaning of symbols	3
1.2	Safety precautions	3
1.3	User responsibility	7
1.4	California Proposition 65 Warning	9
2	INTRODUCTION	11
2.1	Overview	11
2.2	Equipment	11
3	TECHNICAL DATA	12
4	INSTALLATION	14
4.1	Overview	14
4.2	Lifting Instructions	14
5	OPERATION	16
5.1	Overview	16
5.2	Connections and control devices	18
5.3	Water connection	18
5.4	Starting procedure	18
5.5	Explanation of functions	18
5.6	Wire feed pressure	19
5.7	Changing and loading wire	20
5.8	Changing feed rollers	20
6	MAINTENANCE	21
6.1	Overview	21
6.2	Inspection and cleaning	21
7	ORDERING SPARE PARTS	22
	DIAGRAM	23
	WEAR PARTS	25
	ORDER NUMBERS	29
	ACCESSORIES	30

1 SAFETY

1.1 Meaning of symbols

As used throughout this manual: Means Attention! Be Alert!



DANGER!

Means immediate hazards which, if not avoided, will result in immediate, serious personal injury or loss of life.



WARNING!

Means potential hazards which could result in personal injury or loss of life.



CAUTION!

Means hazards which could result in minor personal injury.



WARNING!

Before use, read and understand the instruction manual and follow all labels, employer's safety practices and Safety Data Sheets (SDSs).



1.2 Safety precautions



WARNING!

These Safety Precautions are for your protection. They summarise precautionary information from the references listed in Additional Safety Information section. Before performing any installation or operating procedures, be sure to read and follow the safety precautions listed below as well as all other manuals, material safety data sheets, labels, etc. Failure to observe Safety Precautions can result in injury or death.



PROTECT YOURSELF AND OTHERS

Some welding, cutting and gouging processes are noisy and require hearing protection. The arc, like the sun, emits ultraviolet (UV) and other radiation and can injure the skin and eyes. Hot metal can cause burns. Training in the proper use of the processes and equipment is essential to prevent accidents. Therefore:

1. Wear a welding helmet fitted with a proper shade of filter to protect your face and eyes when welding or watching.
2. Always wear safety glasses with side shields in any work area, even if welding helmets, face shields and goggles are also required.
3. Use a face shield fitted with the correct filter and cover plates to protect your eyes, face, neck and ears from sparks and rays of the arc when operating or observing operations. Warn bystanders not to look at the arc and not to expose themselves to the rays of the electric-arc or hot metal.
4. Wear flameproof gauntlet-type gloves, heavy long-sleeve shirt, cuffless pants, high-topped shoes, and a welding helmet or cap for protection, to protect against arc rays and hot sparks or hot metal. A flameproof apron may also be desirable as protection against radiated heat and sparks.

5. Hot sparks or metal can lodge in rolled up sleeves, trouser cuffs, or pockets. Sleeves and collars should be kept buttoned and open pockets eliminated from the front of the clothing.
6. Protect other personnel from arc rays and hot sparks with a suitable non-flammable partition or curtains.
7. Use goggles over safety glasses when chipping slag or grinding. Chipped slag may be hot and can fly for long distances. Bystanders should also wear goggles over safety glasses.



FIRES AND EXPLOSIONS

The heat from flames and arcs can start fires. Hot slag or sparks can also cause fires and explosions. Therefore:

1. Protect yourself and others from flying sparks and hot metal.
2. Move all combustible materials well away from the work area or cover the materials with a protective non-flammable covering. Combustible materials include wood, cloth, sawdust, liquid and gas fuels, solvents, paints, and coating paper, etc.
3. Hot sparks or hot metal can fall through cracks or crevices in floors or wall openings and cause a hidden smoldering fire or fires on the floor below. Make certain that such openings are protected from hot sparks and metal.
4. Do not weld, cut, or perform other hot work until the work piece has been completely cleaned so that there are no substances on the work piece which might produce flammable or toxic vapors. Do not perform hot work on closed containers, they may explode.
5. Have fire extinguishing equipment handy for instant use, such as a garden hose, water pail, sand bucket, or portable fire extinguisher. Be sure you are trained in its use.
6. Do not use equipment beyond its ratings. For example, an overloaded welding cable can overheat and create a fire hazard.
7. After completing work, inspect the work area to make sure there are no hot sparks or hot metal that could cause a fire later. Use fire watchers when necessary.



ELECTRICAL SHOCK

Contact between live electrical parts and earth can cause severe injury or death. DO NOT use AC welding current in damp areas, if movement is confined, or if there is danger of falling. Therefore:

1. Be sure the power source frame (chassis) is connected to the earth system of the input power.
2. Connect the workpiece to a good electrical earth.
3. Connect the work cable to the workpiece. A poor or missing connection can expose you or others to a fatal shock.
4. Use well-maintained equipment. Replace worn or damaged cables.
5. Keep everything dry, including clothing, work area, cables, torch/electrode holder and power source.
6. Make sure that all parts of your body are insulated from both the work piece and from the ground.
7. Do not stand directly on metal or the ground while working in tight quarters or a damp area; stand on dry boards or an insulating platform and wear rubber-soled shoes.
8. Put on dry, hole-free gloves before turning on the power.
9. Turn off the power, before removing your gloves.
10. Refer to ANSI/ASC Standard Z49.1 for specific grounding recommendations. Do not mistake the work lead for a earth cable.



ELECTRIC AND MAGNETIC FIELDS

May be dangerous. Electric current flowing through any conductor causes localized Electric and Magnetic Fields (EMF). Welding and cutting current creates EMF around welding cables and welding machines. Therefore:

1. Welders with pacemakers fitted should consult their doctor before welding. EMF may interfere with some pacemakers.
2. Exposure to EMF may have other health effects which are unknown.
3. Welders should use the following procedures to minimize exposure to EMF:
 - a) Route the electrode and work cables together. Secure them with tape when possible.
 - b) Never coil the torch or work cable around your body.
 - c) Do not place your body between the torch and work cables. Route cables on the same side of your body.
 - d) Connect the work cable to the workpiece as close as possible to the area being welded.
 - e) Keep the welding power source and cables as far away from your body as possible.



FUMES AND GASES

Fumes and gases, can cause discomfort or harm, particularly in confined spaces. Shielding gases can cause asphyxiation. Therefore:

1. Keep your head out of the fumes. Do not breathe the fumes and gases.
2. Always provide adequate ventilation in the work area by natural or mechanical means. Do not weld, cut or gouge on materials such as galvanized steel, stainless steel, copper, zinc, lead beryllium or cadmium unless positive mechanical ventilation is provided. Do not breathe in the fumes from these materials.
3. Do not operate near degreasing and spraying operations. The heat or arc can react with chlorinated hydrocarbon vapors to form phosgene, a highly toxic gas, and other irritant gases.
4. If you develop momentary eye, nose or throat irritation while operating, this is an indication that the ventilation is not adequate. Stop work and take the necessary steps to improve ventilation in the work area. Do not continue to operate if physical discomfort persists.
5. Refer to ANSI/ASC Standard Z49.1 for specific ventilation recommendations.
6. **WARNING:** This product when used for welding or cutting, produces fumes or gases that contain chemicals known to the State of California to cause birth defects and in some cases cancer (California Health & Safety Code §25249.5 et seq.)



CYLINDER HANDLING

Cylinders, if mishandled, can rupture and violently release gas. A sudden rupture of cylinder valve or relief device can injure or kill. Therefore:

1. Locate cylinders away from heat, sparks and flames. Never strike an arc on a cylinder.
2. Use the proper gas for the process and use the proper pressure reducing regulator designed to operate from the compressed gas cylinder. Do not use adapters. Maintain hoses and fittings in good condition. Follow the manufacturer's operating instructions for mounting a regulator to a compressed gas cylinder.

3. Always secure cylinders in an upright position, by chain or strap, to suitable hand trucks, undercarriages, benches, wall, post or racks. Never secure cylinders to work tables or fixtures where they may become part of an electrical circuit.
4. When not in use, keep cylinder valves closed. Have valve protection cap in place if regulator is not connected. Secure and move cylinders by using suitable hand trucks.



MOVING PARTS

Moving parts, such as fans, rotors and belts can cause injury. Therefore:

1. Keep all doors, panels, guards, and covers closed and securely in place.
2. Stop the engine or drive systems before installing or connecting a unit.
3. Have only qualified people remove covers for maintenance and troubleshooting as necessary
4. To prevent accidental starting of equipment during service, disconnect negative (-) battery cable from battery.
5. Keep hands, hair, loose clothing and tools away from moving parts.
6. Reinstall panels or covers and close doors when service is finished and before starting engine.



WARNING!

FALLING EQUIPMENT CAN INJURE

- Only use lifting eye to lift unit. Do NOT use running gear, gas cylinders or any other accessories.
- Use equipment of adequate capacity to lift and support unit.
- If using lift forks to move unit, be sure forks are long enough to extend beyond opposite side of unit.
- Keep cables and cords away from moving vehicles when working from an aerial location.



WARNING!

EQUIPMENT MAINTENANCE

Faulty or improperly maintained equipment can cause injury or death.

Therefore:

1. Always have qualified personnel perform the installation, troubleshooting and maintenance work. Do not perform any electrical work unless you are qualified to perform such work.
2. Before performing any maintenance work inside a power source, disconnect the power source from the incoming electrical power.
3. Maintain cables, earthing wire, connections, power cord and power supply in safe working order. Do not operate any equipment in faulty condition.
4. Do not abuse any equipment or accessories. Keep equipment away from heat sources such as furnaces, wet conditions such as water puddles, oil or grease, corrosive atmospheres and inclement weather.
5. Keep all safety devices and cabinet covers in position and in good repair.
6. Use equipment only for its intended purpose. Do not modify it in any manner.

**CAUTION!****ADDITIONAL SAFETY INFORMATION**

For more information on safe practices for electric arc welding and cutting equipment, ask your supplier for a copy of “Precautions and Safe Practices for Arc Welding, Cutting and Gouging.” Form 52-529.

The following publications are recommended to you:

1. ANSI/ASC Z49.1 - “Safety in Welding and Cutting”
2. AWS C5.5 - “Recommended Practices for Gas Tungsten Arc Welding”
3. AWS C5.6 - “Recommended Practices for Gas Metal Arc welding”
4. AWS SP - “Safe practices” - Reprint, Welding Handbook
5. ANSI/AWS F4.1 - “Recommended Safe Practices for Welding and Cutting of Containers That Have Held Hazardous Substances”
6. OSHA 29 CFR 1910 - "Safety and health standards"
7. CSA W117.2 - "Code for safety in welding and cutting"
8. NFPA Standard 51B, “Fire Prevention During Welding, Cutting, and Other Hot Work”
9. CGA Standard P-1, “Precautions for Safe Handling of Compressed Gases in Cylinders”
10. ANSI Z87.1, "Occupational and Educational Personal Eye and Face Protection Devices"

1.3 User responsibility

Users of ESAB equipment have the ultimate responsibility for ensuring that anyone who works on or near the equipment observes all the relevant safety precautions. Safety precautions must meet the requirements that apply to this type of equipment. The following recommendations should be observed, in addition to the standard regulations that apply to the workplace.

All work must be carried out by trained personnel well-acquainted with the operation of the equipment. Incorrect operation of the equipment may lead to hazardous situations, which could result in injury to the operator and damage to the equipment.

1. Anyone who uses the equipment must be familiar with:
 - its operation
 - the location of emergency stops
 - its function
 - the relevant safety precautions
 - welding and cutting or other applicable operation of the equipment
2. The operator must ensure that:
 - no unauthorized person is within the working area of the equipment when it is started up
 - no-one is unprotected when the arc is struck or work is started with the equipment
3. The workplace must:
 - be suitable for the purpose
 - be free from drafts

4. Personal safety equipment:
 - Always wear recommended personal safety equipment, such as safety glasses, flame-proof clothing, safety gloves
 - Do not wear loose-fitting items, such as scarves, bracelets, rings, etc., which could become trapped or cause burns
5. General precautions:
 - Make sure the return cable is connected securely
 - Work on high voltage equipment **may only be carried out by a qualified electrician**
 - Appropriate fire extinguishing equipment must be clearly marked and close at hand
 - Lubrication and maintenance must **not** be carried out on the equipment during operation

**WARNING!**

Wire feeders are intended to be used in GMAW (MIG/MAG) mode only.

If used in any other welding mode, such as SMAW (MMA), the welding cable between wire feeder and power source must be disconnected, or else the wire feeder becomes live or energized.

If equipped with ESAB cooler

Use ESAB approved coolant only. Non-approved coolant might damage the equipment and jeopardize product safety. In case of such damage, all warranty undertakings from ESAB cease to apply.

Recommended ESAB coolant ordering number: 0465 720 002.

For ordering information, see the "ACCESSORIES" chapter in the instruction manual.

**WARNING!**

Arc welding and cutting may cause injury to yourself and others. Take precautions when welding and cutting.

**ELECTRIC SHOCK - Can kill**

- Do not touch live electrical parts or electrodes with bare skin, wet gloves, or wet clothing
- Insulate yourself from work and ground.
- Ensure your working position is safe

**ELECTRIC AND MAGNETIC FIELDS - Pose health risks**

- Welders with pacemakers fitted should consult their doctor before welding. EMF may interfere with some pacemakers.
- Exposure to EMF may have other health effects which are unknown.
- Welders should use the following procedures to minimize exposure to EMF:
 - Route the electrode and work cables together on the same side of your body. Secure them with tape when possible. Do not place your body between the torch and work cables. Never coil the torch or work cable around your body. Keep the welding power source and cables as far away from your body as possible.
 - Connect the work cable to the workpiece as close as possible to the area being welded.



FUMES AND GASES - Can be dangerous to your health

- Keep your head out of the fumes
- Use ventilation, extraction at the arc, or both, to take fumes and gases away from your breathing zone and the general area



ARC RAYS - Can injure eyes and burn skin

- Protect your eyes and body. Use the correct welding screen and filter lens and wear protective clothing
- Protect bystanders with suitable screens or curtains



NOISE - Excessive noise can damage hearing

Protect your ears. Use ear defenders or other hearing protection.



MOVING PARTS - Can cause injuries

- Keep all doors, panels and covers closed and securely in place. Have only qualified people remove covers for maintenance and troubleshooting as necessary. Reinstall panels or covers and close doors when service is finished and before starting engine.
- Stop engine before installing or connecting unit.
- Keep hands, hair, loose clothing and tools away from moving parts.



FIRE HAZARD

- Sparks (spatter) can cause a fire. Therefore, make sure that there are no inflammable materials nearby
- Do not use on closed containers.



HOT SURFACE - Parts can burn

- Do not touch parts bare handed.
- Allow cooling period before working on equipment.
- To handle hot parts, use proper tools and/or insulated welding gloves to prevent burns.

MALFUNCTION - Call for expert assistance in the event of malfunction.

PROTECT YOURSELF AND OTHERS!



CAUTION!

This product is solely intended for arc welding.

ESAB has an assortment of welding accessories and personal protection equipment for purchase. For ordering information, contact your local ESAB dealer or visit us on our website.

1.4 California Proposition 65 Warning



WARNING!

Welding or cutting equipment produces fumes or gases that contain chemicals known in the State of California to cause birth defects and, in some cases, cancer. (California Health & Safety Code Section 25249.5 et seq.)



WARNING!

This product can expose you to chemicals including lead, which are known to the state of California to cause cancer and birth defects or other reproductive harm. Wash hands after use.

For more information, go to www.P65Warnings.ca.gov.

2 INTRODUCTION

2.1 Overview

The **Warrior Feed 304**, **Warrior Feed 304w** wire feed unit is intended for GMAW (MIG/MAG) welding together with the welding power sources:

- Warrior 400i CC/CV
- Warrior 500i CC/CV

They are available in different versions, see chapter "ORDERING NUMBER".

The wire feed units are sealed and contain four-wheel drive wire feed mechanisms as well as control electronics.

They can be used together with wire on ESAB's MarathonPac, or on wire bobbin (standard Ø 12 inch, accessory Ø 17 inch).

The wire feed unit can be placed on a trolley, suspended above the workplace with a lifting eye, on a counter balance or on the floor with or without a wheel set.

ESAB accessories for the product can be found in the "ACCESSORIES" chapter of this manual.

2.2 Equipment

The Warrior Feed 304 and Warrior Feed 304w wire feed units are delivered with:

- Instruction manual
- Sticker with recommended wear parts.

3 TECHNICAL DATA

Warrior Feed 304, Warrior Feed 304w	
Power Supply voltage	42 V AC, 50–60 Hz
Power requirement	252 VA
Rated supply current I₁	6 A
Settings data	
Wire feed speed	4.9-82 ft/min (1.5-25.0 m/min)
Creep start	OFF or ON
2/4 stroke	2 stroke or 4 stroke
Wire selection	Solid or Cored
Torch connection	EURO
Max. diameter wire bobbin	300 mm (*440 mm) 12 inch (*17 inch)
Wire dimension	
Fe	.023 - 1/16 inch (0.6-1.6 mm)
SS	.030 - 1/16 inch (0.8-1.6 mm)
Al	.40 & 1/16 inch (1.0 & 1.6 mm)
Cored wire	.035 - 1/16 inch (0.9-1.6 mm)
Weight	
WF 304 with bobbin cover	31.7 lbs (14.4 kg)
WF 304w with bobbin cover	32.4 lbs (14.7 kg)
Weight wire spool (ESAB standard)	
Ø 200 mm	11.0 lbs (5 kg)
Ø 300 mm	39.7 lbs (18 kg)
Ø 440 mm	66.1 lbs (30 kg)
Dimensions (l × w × h)	
basic	26.6 × 10.4 × 16.5 inch (675 × 265 × 418 mm)
Operating temperature	+14° to +104°F (-10° to +40°C)
Transport and storage temperature	-4° to +131°F (-20° to +55°C)
Shielding gas max. pressure	All types intended for GMAW welding 0.5 Mpa (5 bar)
Coolant (Warrior Feed 304w) max. pressure	ESAB's ready-mixed coolant 0.5 Mpa (5 bar)

Warrior Feed 304, Warrior Feed 304w	
Permissible load at	
60% duty cycle	500 A
100% duty cycle	400 A
Enclosure class	IP23
with the Ø 17 inch (Ø 440 mm) bobbin and/or the counterbalance device	IP2X

* See the "ACCESSORIES" chapter in the instruction manual.

Duty cycle

The duty cycle refers to the time, expressed as a percentage of a ten-minute period, during which you can weld or cut at a certain load without overloading. The duty cycle is valid for 104°F (40°C).

Enclosure class

The **IP** code indicates the enclosure class, i.e. the degree of protection against penetration by solid objects or water.

Equipment marked **IP23** is intended for indoor and outdoor use.

Equipment marked **IP2X** is intended for indoor use.

4 INSTALLATION

4.1 Overview

The installation must be carried out by a professional.



WARNING!

When welding in an environment with increased electrical danger, only power sources intended for this environment may be used. These power sources are marked with the symbol **S**.

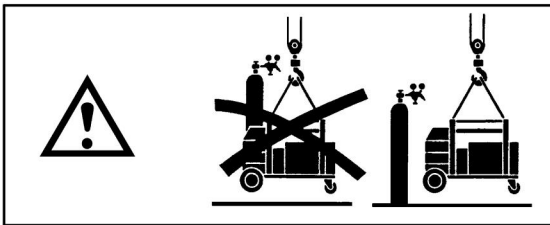

4.2 Lifting Instructions



CAUTION!

Risk of crushing when lifting the wire feeder. Mounting a large wire bobbin (17,32 inch, Ø 440 mm), may change the centre of gravity of the wire feeder and increase the risk of tipping and crushing. Protect yourself and warn bystanders of the risk.



CAUTION!

To avoid personal injury and / or equipment damage, lift using the method and attachment points shown here.

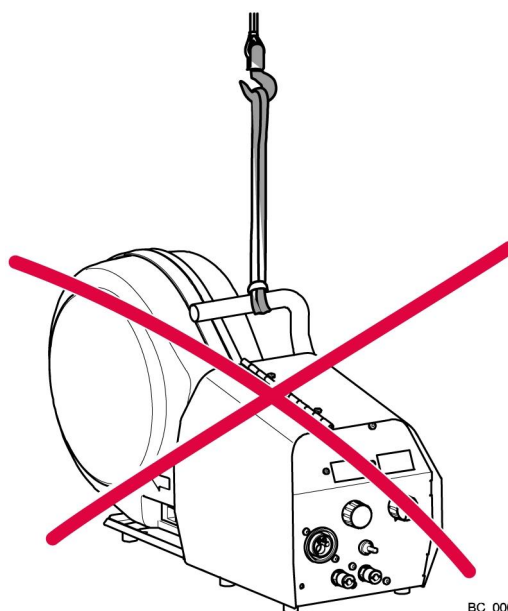
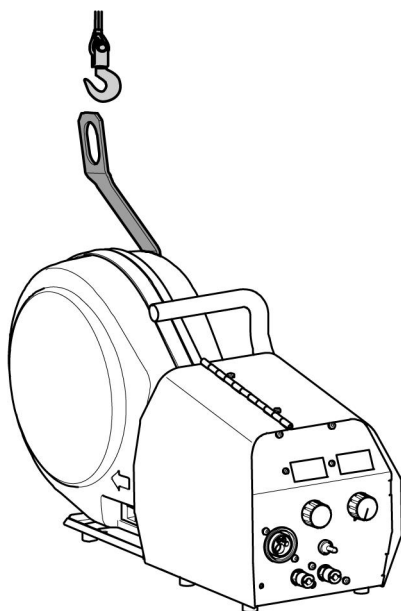

BC_0002

The order number for the lifting eye can be found in the "ACCESSORIES" chapter.



NOTE!

If another mounting device is used, this should be insulated from the wire feed unit.



WARNING!

Secure the equipment - particularly if the ground is uneven or sloping.

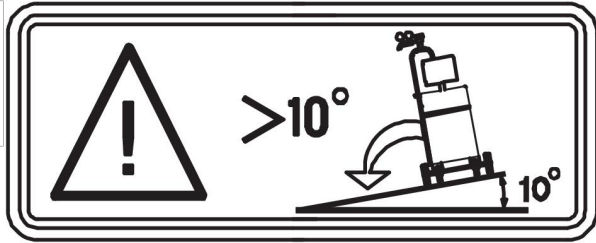

5 OPERATION

5.1 Overview

General safety regulations for handling the equipment can be found in the "SAFETY" chapter of this manual. Read it through before you start using the equipment!



WARNING!

To avoid shock, do not touch the electrode wire or parts in contact with it, or uninsulated cable or connections.



NOTE!

When moving the equipment, use the handle intended for transportation. Never pull the equipment by the welding torch.

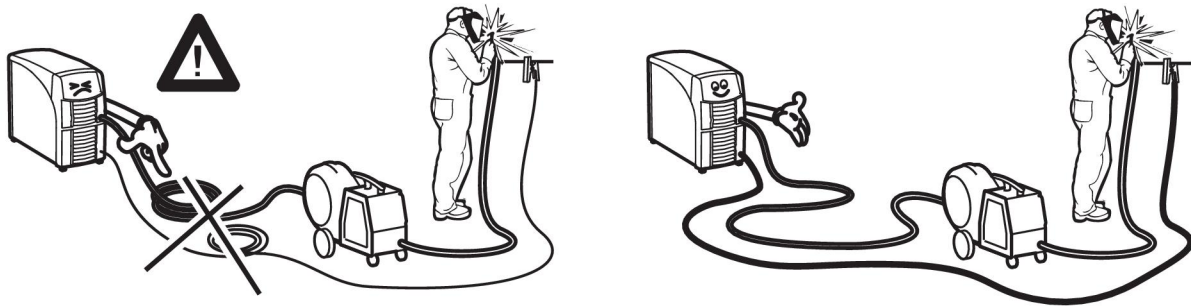

WARNING!

Make sure the side panels are closed during operation.



WARNING!

To prevent the reel from sliding off the hub: Lock the reel in place by turning the red knob as shown on the warning label attached next to the hub.

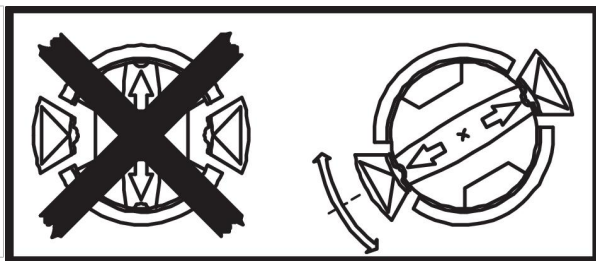

CAUTION!

Before threading welding wire, make sure the chisel point and burrs have been removed from the end of the wire to prevent the wire from jamming in the torch liner.

**WARNING!**

Rotating parts can cause injury, take great care.

**WARNING!**

Risk of crushing when replacing the wire bobbin! Do **not** use safety gloves when inserting the welding wire between the feed rollers.

**WARNING!**

There is a risk of tipping, if the wire feed unit is fitted with a counterbalance arm. Be sure to install the stabilizer kit and secure the equipment, especially if used on an uneven or sloping surface.

Recommended maximum current values for connection set cables

I_{\max}	Cable area	Cable length	Note
450 A (60% duty cycle)	70 mm ²	6.6 ft–114.8 ft (2–35 m)	19 pole
350 A (100% duty cycle)			
550 A (60% duty cycle)	95 mm ²	6.6 ft–114.8 ft (2–35 m)	19 pole
430 A (100% duty cycle)			
450 A (60% duty cycle)	70 mm ²	6.6 ft–114.8 ft (2–35 m)	19 pole, water
350 A (100% duty cycle)			
550 A (60% duty cycle)	95 mm ²	6.6 ft–114.8 ft (2–35 m)	19 pole, water
430 A (100% duty cycle)			

Duty cycle

The duty cycle refers to the time as a percentage of a ten-minute period that you can weld or cut at a certain load without overloading. The duty cycle is valid for 104°F (40°C).

5.2 Connections and control devices

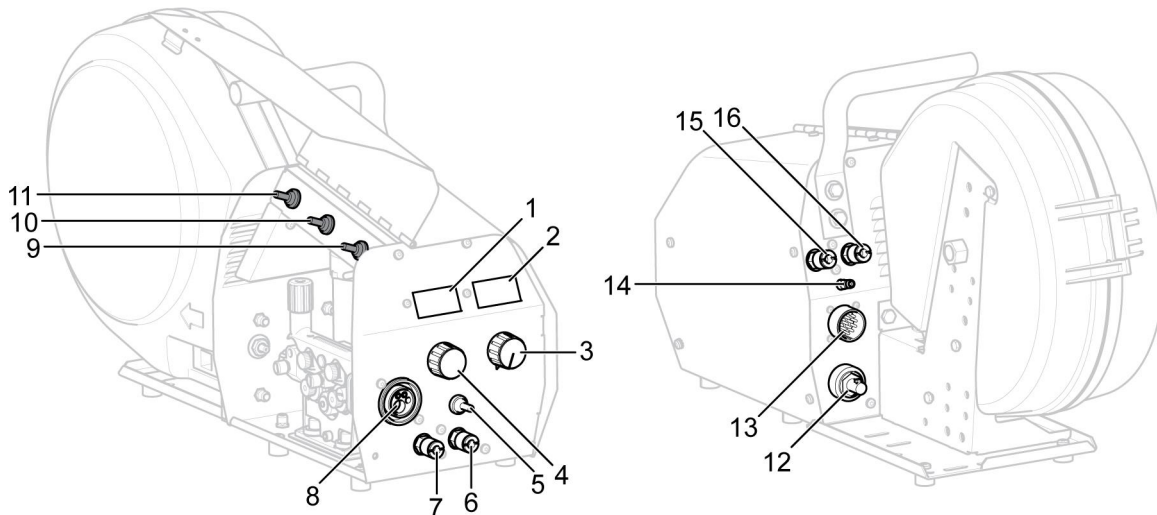

- | | |
|--|---|
| 1. Display voltage (V) | 9. Switch for 4 stroke / 2 stroke (inside) |
| 2. Display current (A) | 10. Switch for Cored wire / Solid wire (inside) |
| 3. Knob for setting the wire feed speed | 11. Switch for Creep start (inside) |
| 4. Knob for setting the voltage | 12. Connection for welding current from power source (OKC) |
| 5. Switch for wire inching or gas purge | 13. Connection for control cable from power source |
| 6. RED connection for cooling water from welding torch *) | 14. Connection for shielding gas |
| 7. BLUE connection for cooling water to the welding torch *) | 15. BLUE connection for cooling water from power source (cooling unit) *) |
| 8. Connection for the welding torch | 16. RED connection for cooling water to power source (cooling unit) *) |



NOTE!

*) Cooling water connections are only available on certain models.

5.3 Water connection

When connecting a water-cooled welding torch, the power source's main power supply switch must be in the OFF position and the cooling unit switch must be in position 0.

A water connection kit can be ordered as an accessory, see chapter "Accessories".

5.4 Starting procedure

When the wire feed starts, the power source generates the welding voltage.

If there is no welding current flow within three seconds, the power source switches the welding voltage off. The wire feed continues until the welding torch's switch is switched to off.

5.5 Explanation of functions

Open the lid for access to the 4 stroke/2 stroke, the Cored/Solid wire and the Creep start functions.

**2-stroke**

With 2-stroke gas, pre-flow (if used) starts when the welding torch trigger switch is pressed. The welding process then starts. Releasing the trigger switch stops welding entirely and starts gas post-flow (if selected).

**4-stroke**

With 4 stroke, the gas pre-flow starts when the welding torch trigger switch is depressed and the wire feed starts when it is released. The welding process continues until the switch is pressed in again, the wire feed then stops and when the switch is released the gas post-flow starts (if selected).

**Wire selection – Cored wire**

A constant burnback time is selected when the trigger is released, to adjust to welding with cored wire.

**Wire selection – Solid wire**

Short Circuit Termination (SCT) behavior is selected when the trigger is released, to adjust to welding with solid wire.

SCT is a new way to stop the welding that uses some small short circuits to reduce the end crater and oxidation. It also gives the advantage of a good start performance with solid wire.

**Creep start**

Creep start feeds out the wire at 4.9 ft/min (1.5 m/min) until it makes electrical contact with the workpiece.

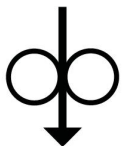
**Wire inching**

Wire inching is used when feeding wire without applying a welding voltage. The wire is fed as long as the button is depressed.

**Gas purging**

Gas purging is used when measuring the gas flow, or to flush any air or moisture from the gas hoses before welding starts. Gas purging takes place for as long as the button is held depressed and takes place without voltage or wire feed starting.

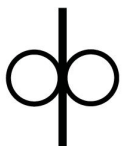
**Wire feed speed**

This sets the required feed speed of the filler wire in inches per minute (in/min) or meters per minute (m/min).

5.6 Wire feed pressure

Start by making sure that the wire moves smoothly through the wire guide. Then set the pressure of the wire feeder's pressure rollers. It is important that the pressure is not too high.

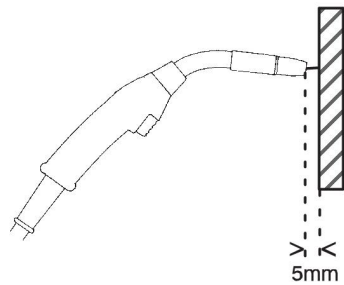

Figure A

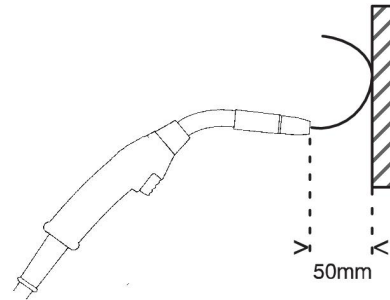

Figure B

To check that the feed pressure is set correctly, you can feed out the wire against an insulated object, e.g. a piece of wood.

When you hold the welding torch approx. 5 mm from the piece of wood (figure A) the feed rollers should slip.

If you hold the welding torch approx. 50 mm from the piece of wood, the wire should be fed out and bend (figure B).

5.7 Changing and loading wire

- Open the side panel.
- Disconnect the pressure sensor by folding it backward; the pressure rollers slide up.
- Straighten out the new wire 4-8 in (10-20 cm). File away burrs and sharp edges from the end of the wire before inserting it into the wire feed unit.
- Make sure that the wire goes properly into the feed roller's track and into the outlet nozzle or wire guide.
- Secure the pressure sensor.
- Close the side panel.

5.8 Changing feed rollers

- Open the side panel.
- Disconnect the pressure sensor (1) by folding it backwards.
- Disconnect the pressure rollers (2) by turning the axle (3) 1/4 turn clockwise and pulling out the axle.

The pressure rollers disconnect

- Disconnect the feed rollers (4) by unscrewing the nuts (5) and pulling out the rollers.

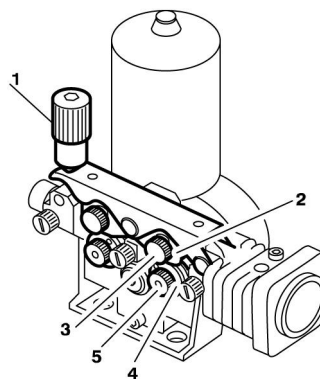

During installation, repeat the above in reverse order.

Choice of track in the feed rollers

Turn the feed roller with the dimensioning mark for the required track toward you.

6 MAINTENANCE

6.1 Overview



NOTE!

Regular maintenance is important for safe and reliable operation.



CAUTION!

All warranty undertakings from the supplier cease to apply if the customer attempts any work to rectify any faults in the product during the warranty period.

6.2 Inspection and cleaning

Wire feed unit

Check regularly that the wire feed unit is not clogged with dirt.

- Cleaning and replacement of worn parts in the wire feed unit mechanism should be done at regular intervals in order to achieve trouble-free wire feed. Note that if the pre-tensioning is set too hard, this can result in abnormal wear on the pressure roller, feed roller and wire guide.

The brake hub

The hub is adjusted when delivered, if readjustment is required, follow the instructions below. Adjust the brake hub so the wire is slightly slack when the wire feed stops.

- **Adjusting the braking torque:**
 - Turn the red handle to the locked position.
 - Insert a screwdriver into the springs in the hub.

Turn the springs clockwise to reduce the braking torque.

Turn the springs counter-clockwise to increase the braking torque.

Note: Make sure you turn both springs by the same amount.

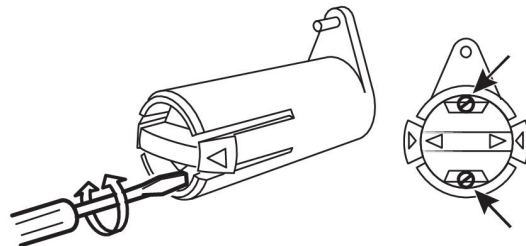

Welding torch

- Cleaning and replacement of the wear parts in the welding torch should be done at regular intervals in order to achieve trouble-free wire feed. Blow the wire guide clean regularly and clean the contact tip.

7 ORDERING SPARE PARTS



CAUTION!

Repair and electrical work should be performed by an authorised ESAB service technician. Use only ESAB original spare and wear parts.

The Warrior Feed 304 is designed and tested in accordance with international and European standard **IEC/EN 60974-5** and **IEC/EN 60974-10 Class A**, Canadian standard **CAN/CSA-E60974-5** and U.S. standard **ANSI/IEC 60974-5**. Upon completion of service or repair work, it is the responsibility of the person(s) performing the work to ensure that the product still complies with the requirements of the above standards.

Spare parts and wear parts can be ordered through your nearest ESAB dealer, see the back cover of this document. When ordering, please state product type, serial number, designation and spare part number in accordance with the spare parts list. This facilitates dispatch and ensures correct delivery.

DIAGRAM

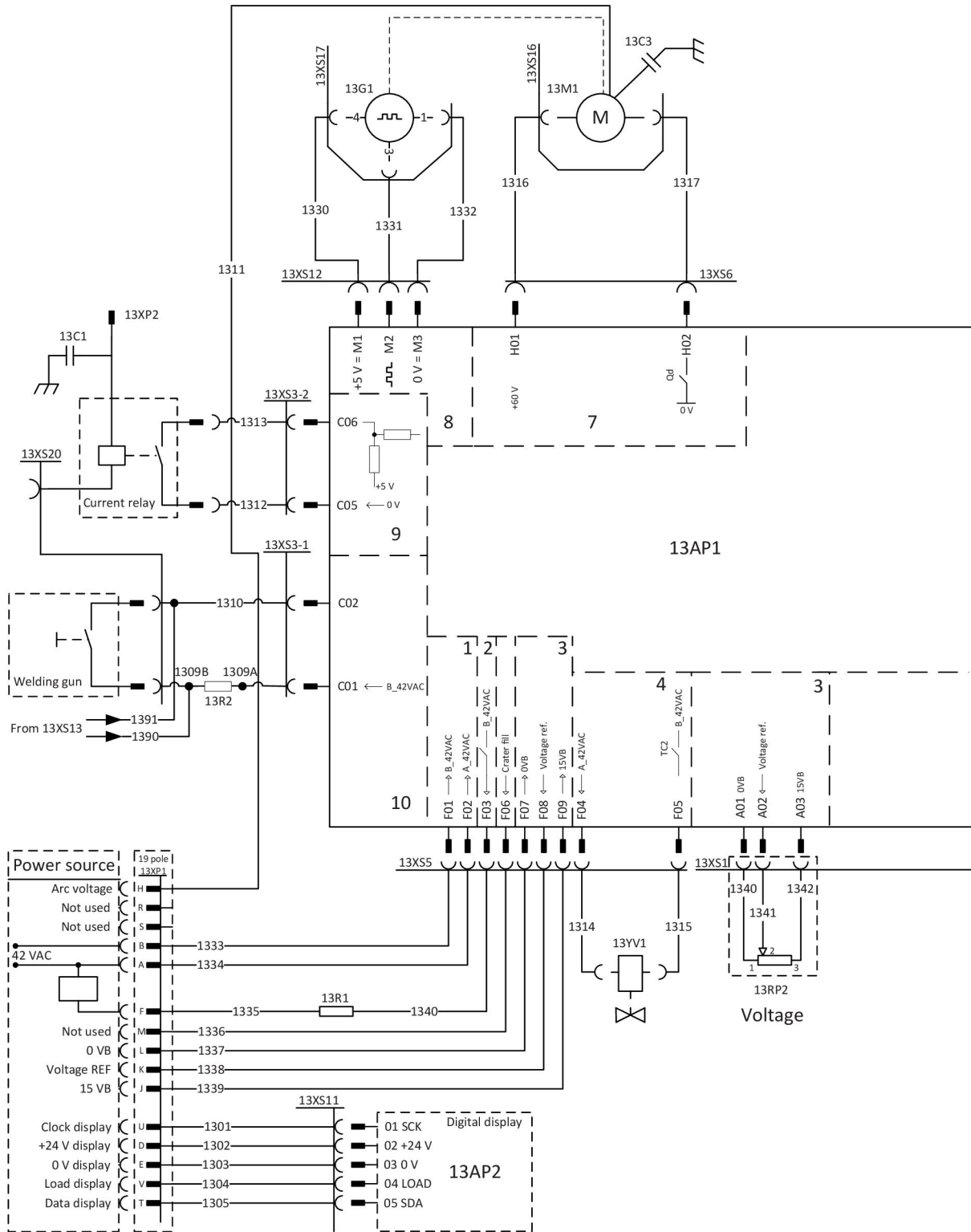

DIAGRAM

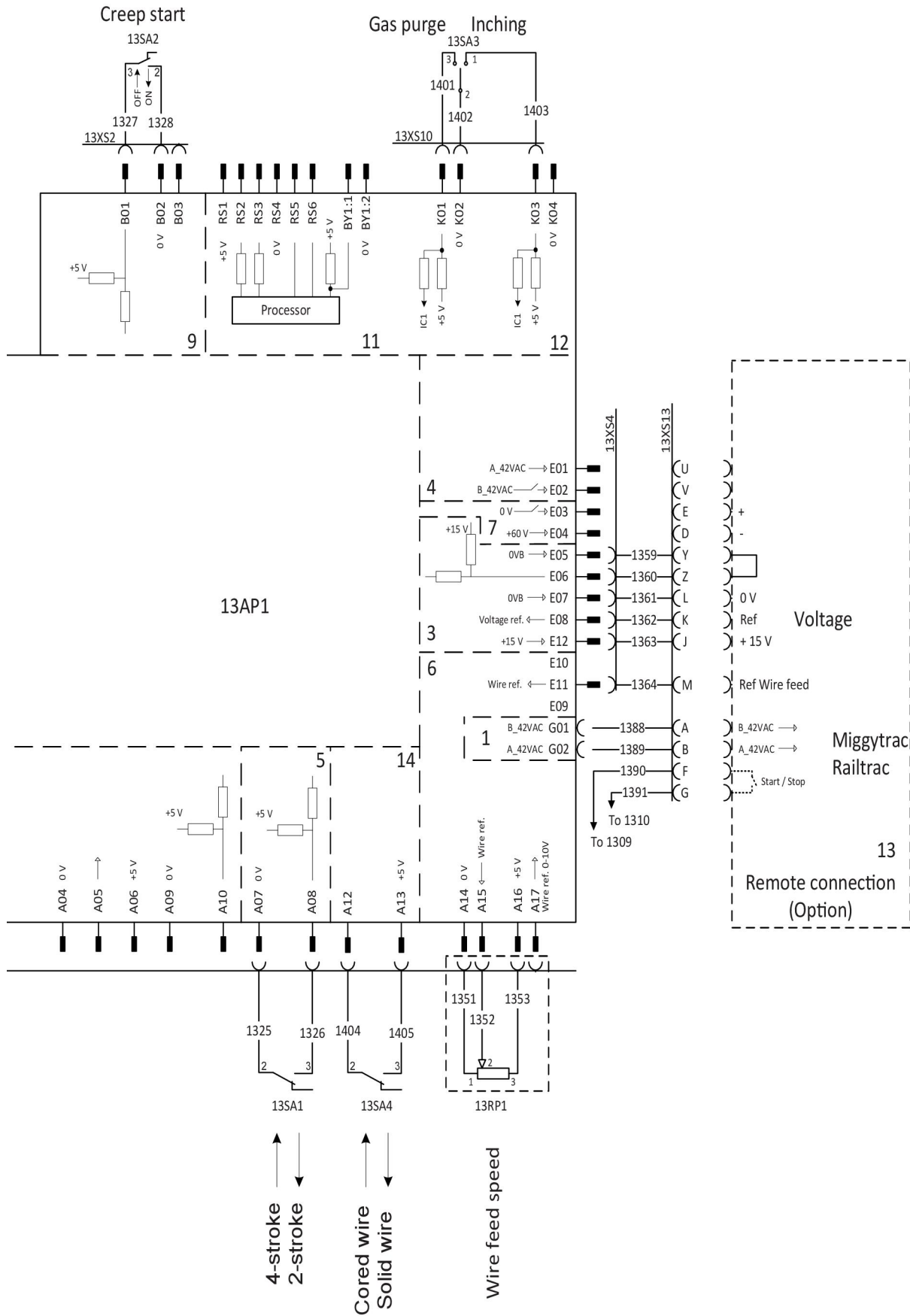

WEAR PARTS

Item	Ordering number	Denomination	Wire type	Wire dimensions
HI 1	0455 072 002 0456 615 001	Intermediate nozzle Intermediate nozzle	Fe, Ss & cored Al	Ø 2.0 mm steel for 0.6-1.6 mm Ø 2.0 mm plastic for 0.8-1.6 mm
HI 2	0469 837 880 0469 837 881	Outlet nozzle Outlet nozzle	Fe, Ss & cored Al	Ø 2.0 mm steel for 0.6-1.6 mm Ø 2.0 mm plastic for 0.8-1.6 mm
HI 3	0191 496 114	Key		
HI 4	0215 701 007	Locking washer		
HI 5a	0459 440 001	Motor gear euro, drive gear		

Item	Ordering number	Denomination	Wire type	Wire dimensions (mm)	Groove type	Roller markings
HI 5b	0459 052 001	Feed/pressure rollers	Fe, Ss & cored	Ø 0.6 & 0.8	V	0.6 S2 & 0.8 S2
	0459 052 002	Feed/pressure rollers	Fe, Ss & cored	Ø 0.8 & 1.0	V	0.8 S2 & 1.0 S2
	0459 052 003	Feed/pressure rollers	Fe, Ss & cored	Ø 0.9/1.0 & 1.2	V	1.0 S2 & 1.2 S2
	0459 052 013	Feed/pressure rollers	Fe, Ss & cored	Ø 1.4 & 1.6	V	1.4 S2 & 1.6 S2
	0458 825 001	Feed/pressure rollers	Cored	Ø 0.9/1.0 & 1.2	V- knurled	1.0 R2 & 1.2 R2
	0458 825 010	Feed/pressure rollers	Cored	Ø 1.2 & 1.2	V- knurled	1.2 R2 & 1.2 R2
	0458 825 002	Feed/pressure rollers	Cored	Ø 1.2 & 1.4	V- knurled	1.2 R2 & 1.4 R2
	0458 825 003	Feed/pressure rollers	Cored	Ø 1.6	V- knurled	1.6 R2 & 2.0 R2
	0458 824 001	Feed/pressure rollers	Al	Ø 0.8 & 0.9/1.0	U	0.8 A2 & 1.0 A2
	0458 824 002	Feed/pressure rollers	Al	Ø 1.0 & 1.2	U	1.0 A2 & 1.2 A2
	0458 824 003	Feed/pressure rollers	Al	Ø 1.2 & 1.6	U	1.2 A2 & 1.6 A2

Only use pressure and feed rollers marked **A2**, **R2** or **S2**.
The rollers are marked with wire dimension in mm, some are also marked with inch.

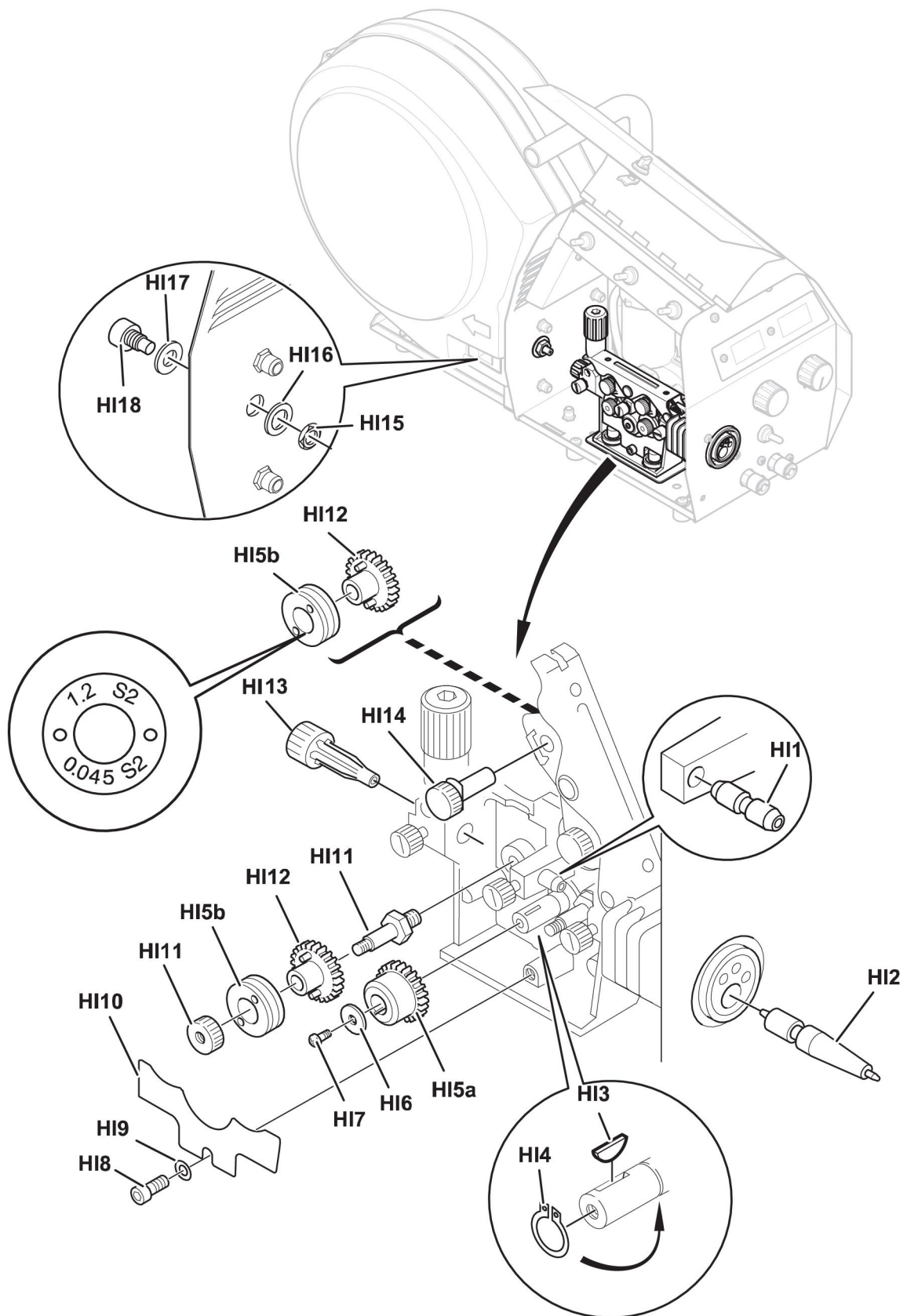

WEAR PARTS

Item	Ordering number	Denomination	Notes
HI 6		Washer	Ø 16/5×1
HI 7		Screw	M4×12
HI 8		Screw	M6×12
HI 9		Washer	Ø 16/8.4×1.5
HI 10	0469 838 001	Cover	
HI 11	0458 722 880	Axle and Nut	
HI 12	0459 441 880	Gear adapter	
HI 13	0455 049 001	Inlet nozzle	Ø 3mm for 0.6-1.6mm Fe, Ss, Al and cored wire
	0460 007 001	Inlet nozzle	Long-life for Fe, Ss, and cored wire
HI 14	0458 999 001	Shaft	
HI 15		Nut	M10
HI 16	0458 748 002	Insulating washer	
HI 17	0458 748 001	Insulating bushing	

Item	Ordering number	Denomination	Wire type	Wire dimensions
HI 18	0156 602 001	Inlet nozzle	Ø 16/5×1	Ø 2 mm plastic for 0.6 - 1.6 mm

Welding with aluminium wire

In order to weld with aluminium wire, U-shaped rollers, nozzles and liners for aluminium wire **must** be used. It is recommended to use 3 m long welding torch for aluminium wire, equipped with appropriate wear parts.

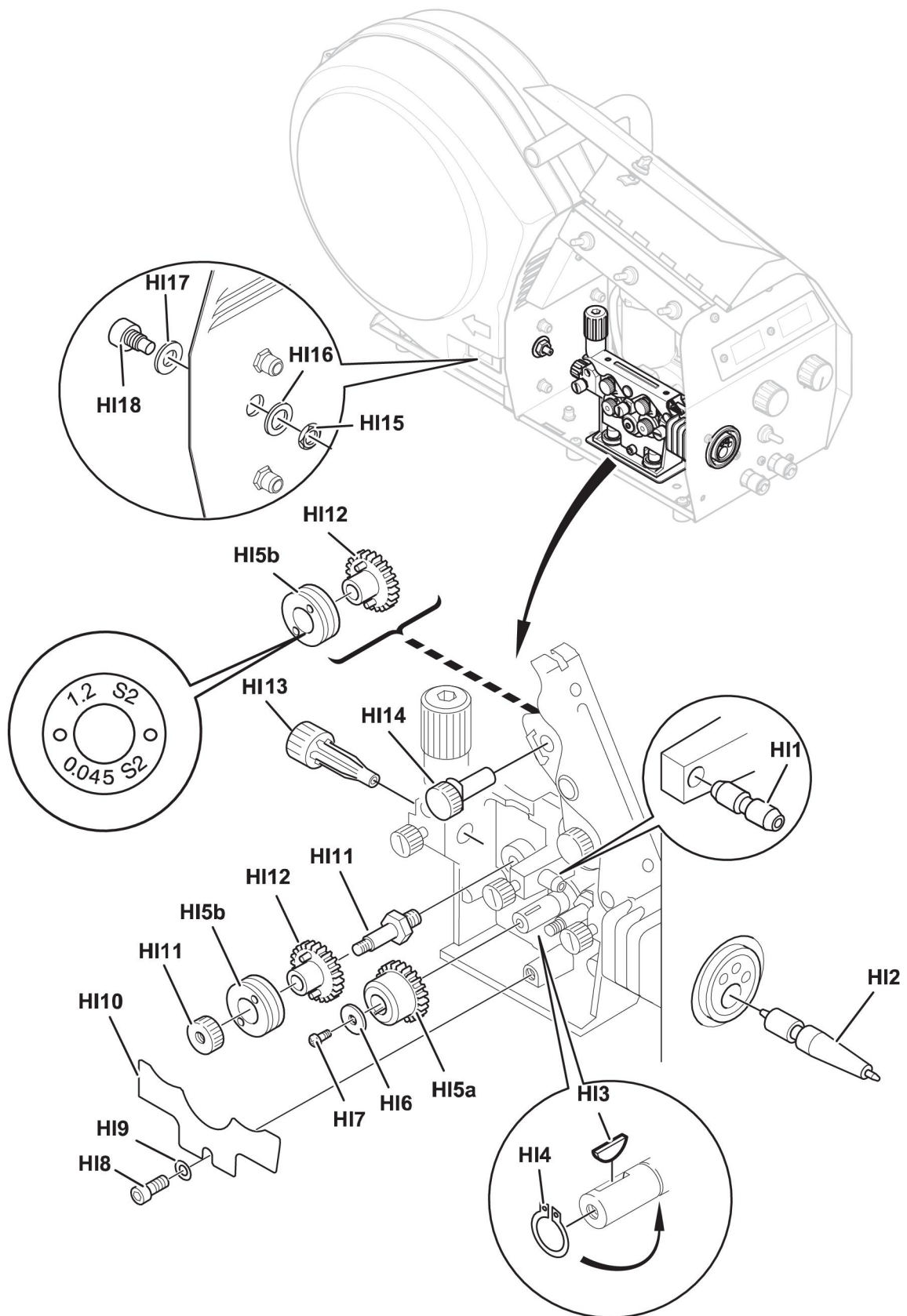

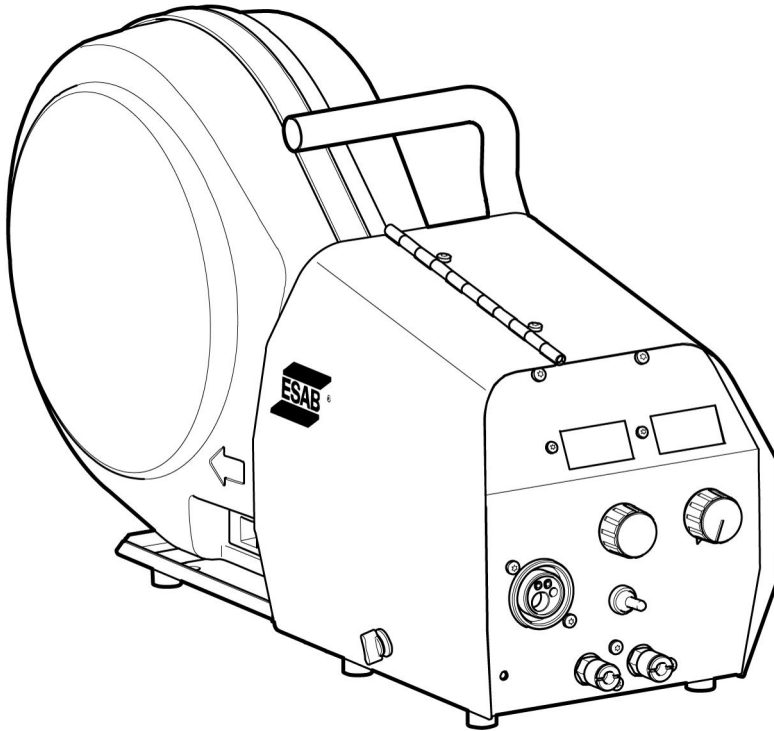

ORDER NUMBERS



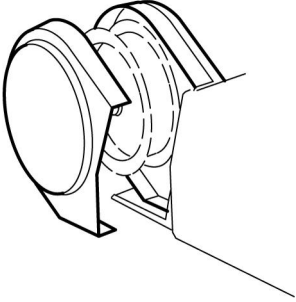
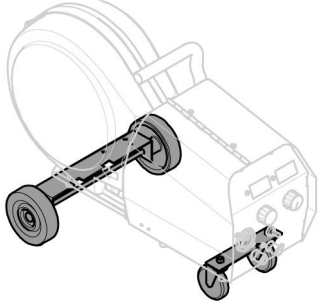
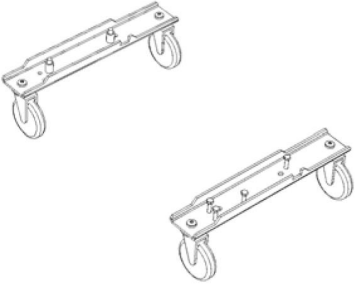
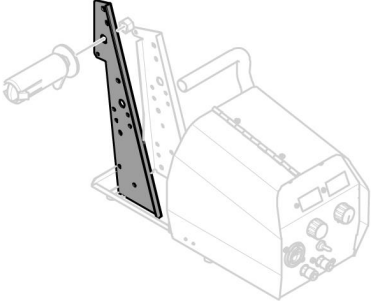

Ordering Number	Denomination	Type
0465 250 880	Warrior™ Feed 304	
0465 250 881	Warrior™ Feed 304w	with water cooling
0459 839 085	Spare parts list	

Technical documentation is available on the Internet at www.esab.com.

ACCESSORIES

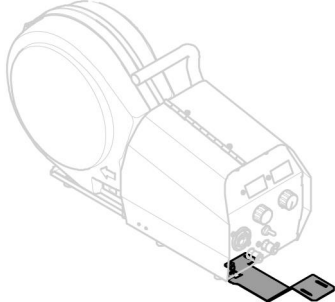
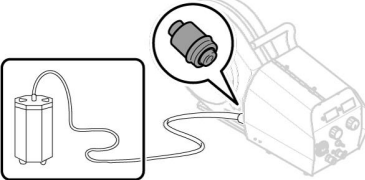
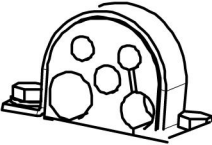
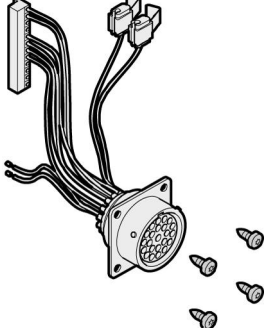
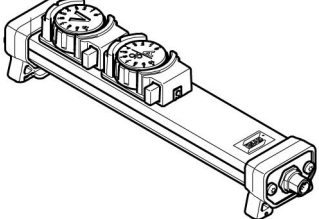
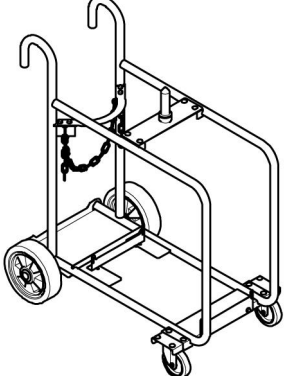
0458 674 880	Bobbin cover kit, plastic Ø 300 mm	
0458 707 880	Wheel kit	
0458 707 881	Wheel kit	
0459 233 880	Adapter for Ø 440 mm bobbin Note! IP23 not valid for wire feeder with Ø 17,32 Inch (400 mm) bobbin.	
0458 706 880	Lifting eye	

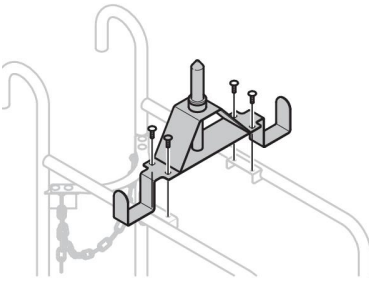
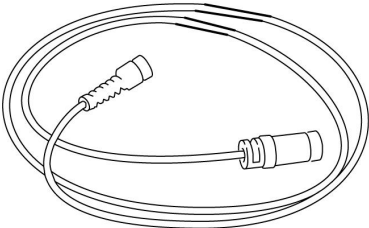
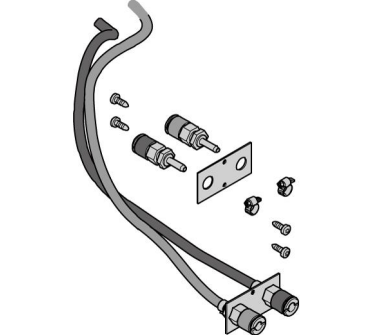
0457 341 881	Strain relief for welding torch	
F102 440 880	Quick connector MarathonPac™	
0459 234 880	Strain relief bracket for connection set	
0465 451 880	Remote kit	
0459 491 895	Remote control unit M1 MIG/MAG: wire feed speed and voltage	
0465 510 880	Trolley	

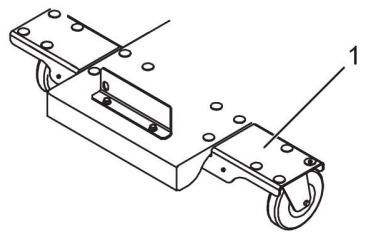
<p>0465 508 880</p>	<p>Trolley guide pin extension kit Used together with the trolley when the wire feed unit is equipped with wheel kit</p>	
<p>0459 553 880</p>	<p>Remote cable 23 pole - 8 pole 5 m</p>	
<p>0465 276 881</p>	<p>Water kit</p>	
<p>0458 705 880</p>	<p>Counter balance device (includes mast and counter balance) Note! For use of the counter balance device, a stabilizer kit (see below) is required! Note! IP23 not valid for wire feeder with counterbalance arm.</p>	
<p>0465 509 880</p>	<p>Stabilizer kit Warrior™ (1)</p>	

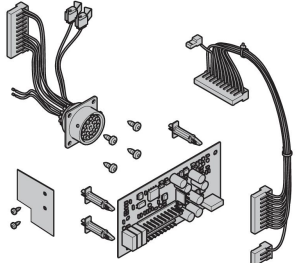
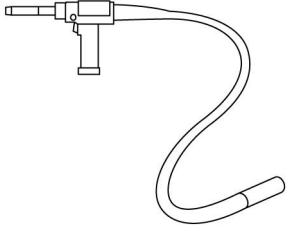
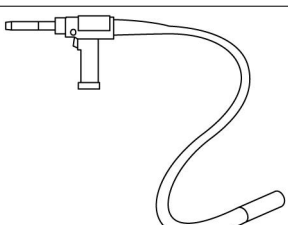
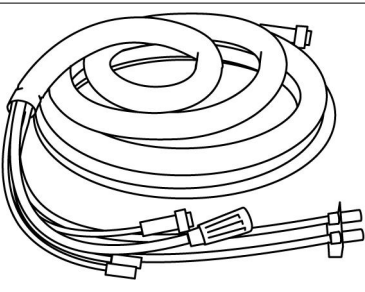
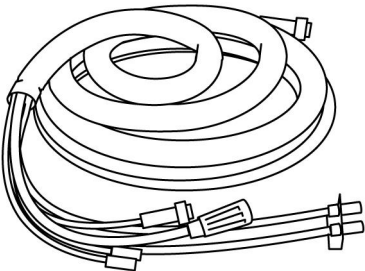
0465 451 881	Remote Kit Railtrac / Miggytrac	
Welding torch MXH 400w PP Note! MXH PP only recommended for Feed304/3004/L3004		
0700 200 015	6 m	
0700 200 016	10 m	
0700 200 019	10 m, 45°	
Welding torch MXH 300w PP Note! MXH PP only recommended for Feed304/3004/L3004		
0700 200 017	6 m	
0700 200 018	10 m	
0700 200 020	10 m, 45°	
Connection set, 70 mm², 19 poles		
0459 836 880	2 m	
0459 836 881	5 m	
0459 836 882	10 m	
0459 836 883	15 m	
0459 836 884	25 m	
0459 836 885	35 m	
Connection set water, 70 mm², 19 poles		
0459 836 890	2 m	
0459 836 891	5 m	
0459 836 892	10 m	
0459 836 893	15 m	
0459 836 894	25 m	
0459 836 895	35 m	

Connection set, 95 mm², 19 poles	
0459 836 980	2 m
0459 836 981	5 m
0459 836 982	10 m
0459 836 983	15 m
0459 836 984	25 m
0459 836 985	35 m

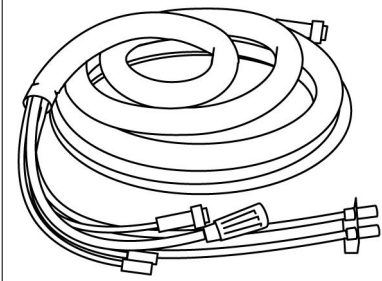

Connection set water, 95 mm², 19 poles	
0459 836 990	2 m
0459 836 991	5 m
0459 836 992	10 m
0459 836 993	15 m
0459 836 994	25 m
0459 836 995	35 m

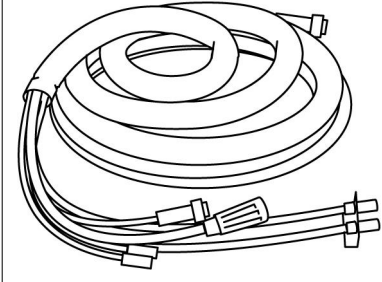



A WORLD OF PRODUCTS AND SOLUTIONS.



For contact information visit esab.com

ESAB AB, Lindholmsallén 9, Box 8004, 402 77 Gothenburg, Sweden, Phone +46 (0) 31 50 90 00

<http://manuals.esab.com>

